

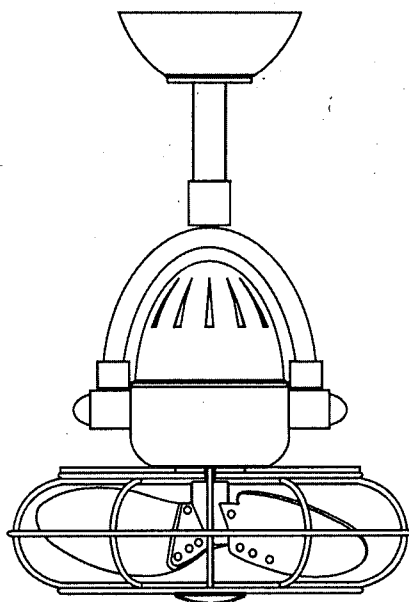

Diane

Ceiling Mounted Oscillating Directional Fan

READ AND SAVE THESE INSTRUCTIONS



**FAN RATING AC 120V. 60Hz
MODEL : AC-MGB2**

TOOLS AND MATERIALS REQUIRED

- Philips screw driver
- Standard, flat-head screw driver
- 11 mm wrench
- Step ladder
- Wire cutters

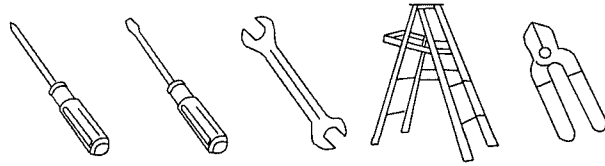

PACKAGE CONTENTS

Unpack your fan and check the contents. You should have the following items:

- a. Hanger bracket assembly
- b. Ball / down rod assembly
- c. Fan motor assembly
- d. Metal blade with cage (decorative* or safety**) or Wood blade
- e. Receiver with 6 wire nuts
- f. Transmitter+holder+2 mounting screws
- g. Allen wrench
- h. Package hardware
 - 1) Mounting hardware: wood screws (2), screws (2), lock washers (2), washers (2), star washers (2), wire nuts (3)

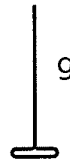
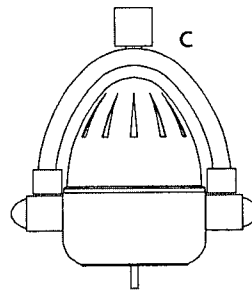
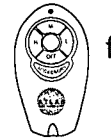
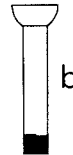
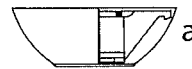

*If blade is metal and accompanied by safety cage (see Diagram d-i): To reduce the risk of injury to persons, install fan so that blade are at least 7.0 Ft. above the floor in the US and 8.3 Ft./2.5 M above the floor in Canada.

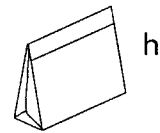
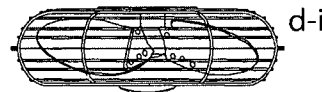

**If blade is metal and accompanied by decorative cage (See Diagram d-ii) or unguarded wooden blade (See Diagram d-iii): To reduce the risk of injury to persons, install fan so that blade is at least 10.0 Ft. above the floor in the US and 10.0 Ft./3.05 M above the floor in Canada.

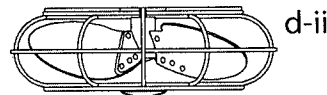

READ AND SAVE THESE SAFETY AND INSTALLATION INSTRUCTIONS.

**Consult a licensed electrician if unsure of any point below mentioned.
DANGER/WARNING/CAUTION**

1. High voltage and moving parts around motors and motor driven equipment can cause serious or fatal injuries. Always disconnect power source at main switch before wiring, servicing or cleaning unit. Do not rely on fan control device to prevent unexpected start-up or electrical shock. In addition, power supply must have fuses or circuit breakers for short circuit protection.
2. All electrical wiring must conform to national and local electrical codes such as: NEC, OSHA, etc.
3. Fan should be secure in its electrical grounding to avoid possible electrical shock.
4. Fan should not be used in any wet or hazardous location defined by article 500 of the NEC. In addition, its ambient temperature should not exceed 104 degrees Fahrenheit.
5. Power supply should conform to voltage rating of 120V.
6. Before applying power, visually re-inspect the installation. Make sure that all guards and protective devices are securely in place and all visible screws and bolts are tightened.
7. **Warning:** to reduce the risk of fire, electrical shock or personal injury, mount hanging bracket to outlet box marked "Acceptable for fan support and a hanging weight of 45 Lbs." Do not mount fan to sheet rock or drywall type materials and use only the screws provided with the outlet box.
8. **Caution:** to reduce the risk of injury to persons, install fan so that bottom edges of fan blades are to be:

**In Canada, to satisfy CSA requirements: at least 8.3 Ft/2.5 M above the floor and all objects in room if safety cages are utilized. 10.0 Ft if safety cages are not utilized.
**In the US, to satisfy UL requirements: at least 7.0 Ft above the floor and all objects in room if safety cages are utilized. 10.0 Ft. if safety cages are not utilized.
9. To reduce the risk of personal injury, do not bend blades or any other part of fan when cleaning. Do not insert foreign objects in between rotating fan blades or in space surrounding entire rotating fan unit. Fan must be turned off at power at supply source before installation, cleaning or servicing.
10. **Instructions for Supply Connections:** Conductor of a fan identified as grounded conductor to be connected to a grounded conductor of a power supply, conductor of fan identified as ungrounded conductor to be connected to an ungrounded conductor of a power supply, conductor of fan identified for equipment grounding to be connected to an equipment-grounding conductor. After making the wire connections in junction box, the splices should be turned upward and pushed carefully into the outlet box. The wires should be spread apart with the grounded conductor and the fan-grounding conductor on one side of the junction box and the ungrounded conductor on the other side of the outlet box. Be sure that all wiring connections are properly insulated from each other and any surrounding metal parts. For safety and best operating results, we recommend that you have a qualified electrician assemble and install your fan.

11. To reduce the risk of personal injury, install the supplementary mounting means and use only the hardware provided with the fan.
12. **Warning:** TO REDUCE THE RISKS OF FIRE, ELECTRIC SHOCK OR INJURY TO PERSONS, OBSERVE THE FOLLOWING:
 - A. Use this unit only in the manner intended by the manufacturer. If you have any questions, contact the manufacturer.
 - B. Before installing, servicing or cleaning unit, switch power off at service panel and lock service panel to prevent power from being switched on accidentally.
13. **Warning:** To reduce the risk of fire, electrical shock or personal injury, mount to outlet box marked acceptable for fan support and use screws provided with outlet box.

JUNCTION BOX MOUNTING OPTIONS

Your new ceiling fan will require a grounded electrical supply line of 120 volts AC, 60 Hz circuit. The outlet box must be securely anchored and capable of withstanding a load of at least 45 lbs.

Figures 1, 2 and 3 are examples of different ways to mount the outlet box.

Note: You may need a longer down rod to maintain proper blade clearance when installing on a steep, sloped ceiling. (Fig. 3)

To hang your fan where there is an existing fixture but no ceiling joist, you may need an installation hanger bar as shown in Fig. 4.

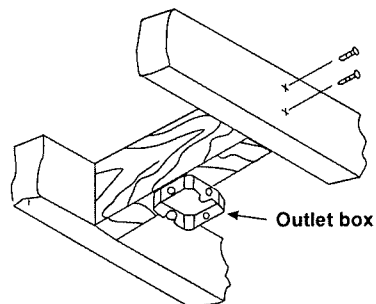

Figure 1

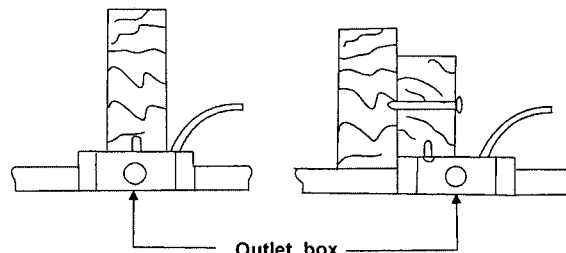

Figure 2

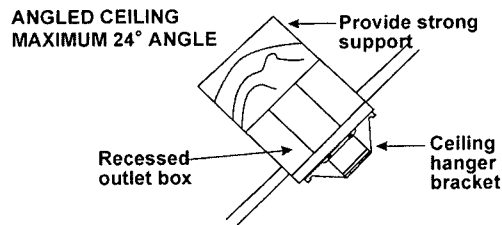

Figure 3

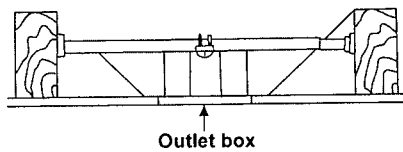

Figure 4

MOUNTING/INSTALLATION OF THE FAN

Before touching a screw driver thoroughly read these instructions.

Warning/Caution: Before installing fan, turn off power at service panel and check all visible screws and bolts for tightness.

1. Remove the decorative canopy bottom cover from the canopy by turning the cover counter clockwise. (Fig. 5)

2. Remove the hanger bracket from the canopy by removing the 1 of 2 screws from the bottom of the hanger bracket and loosening the other one a half turn from the screw head. Next, turn the canopy counter clockwise to removing the hanger bracket from the canopy. (Fig. 5)

3. Secure the hanger bracket to the ceiling outlet box using screws and washers included with your outlet box. (Fig. 6)

4. Remove hanger ball from down rod assembly by loosening set screws, removing the cross pin and sliding ball off rod. (Fig. 7)

5A. Metal Blade Head and Decorative Cage:

If your fan is one with a metal blade head and decorative cage, remove protective plastic sleeve from the motor shaft, and then attach the metal blade head and cage. The Atlas medallion should be oriented correctly. Handle your blade head carefully otherwise you will bend the blade irons and cause your fan to vibrate when in use. Caution: The set screw in the blade head hub must be counter-sunk into the bore-hole on the flattened side of the motor shaft - or else the blade head may disengage from the motor shaft during operation.

5B. Metal Blade Head and Safety Cage: If your fan is one with a metal blade head and safety cage, remove protective plastic sleeve from the motor shaft, then and attach the back side of the safety cage. Next, attach the blade head. Handle your blade head carefully otherwise you will bend the blade irons and cause your fan to vibrate when in use. Finally attach the front side of the cage with Atlas medallion oriented correctly. Caution: The set screw in the blade hub must be counter-sunk into the bore-hole on the flattened side of the motor shaft - or else the blade head may disengage from the motor shaft during operation.

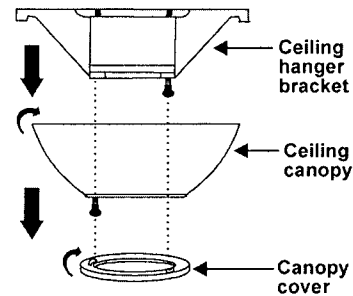

Figure 5

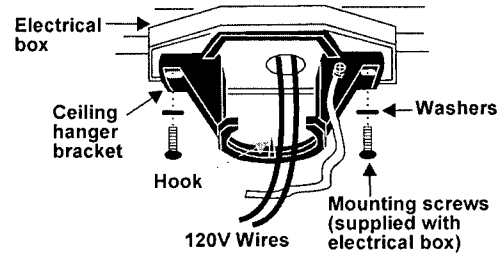

Figure 6

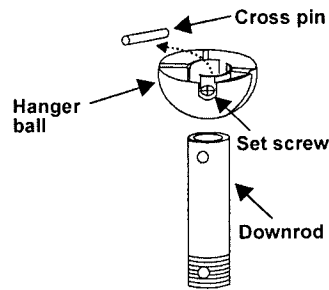

Figure 7

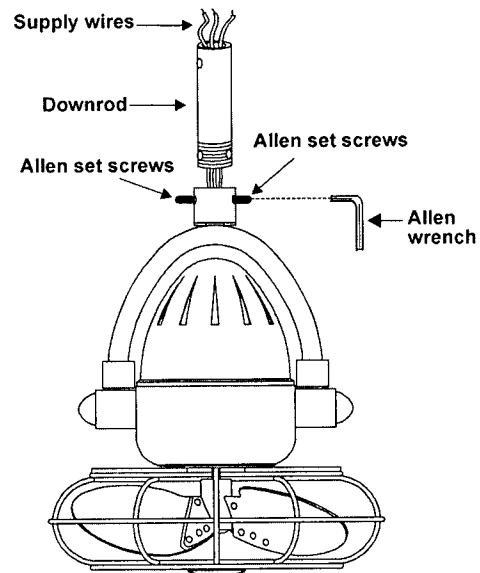

Figure 8

5 C. Wooden Blade Head: If your fan is one with wooden blade head, attach your blades as the last step in the assembly process. Do not attach them now. Attach them in step No.: 9. Handle your blade head carefully otherwise you will bend the blade irons and cause your fan to vibrate when in use.

6. Loosen the two set screws from the top coupling of the motor assembly. (Fig. 8)

7. Carefully feed the fan wires up through the down rod. Thread the down rod into the coupling then tighten the set screws using the Allen wrench. (Fig. 8) Carefully reinstall hanger ball onto rod being sure that cross pin is in correct position, the set screw on hanger ball is tight and wires are not twisted.

8. Now lift the motor assembly into position and place the hanger ball into the hanger bracket. Rotate until the "Check Tab" has dropped into the "Registration Slot" and seats firmly. The entire motor assembly should not rotate if this is done correctly.

9. Remove protective plastic sleeve from the motor shaft and attach your wooden blades. Ignore this step if you have metal blades, as they should already have been installed. Make sure that the set screw in the blade hub is counter-sunk into the bore-hole into the shaft of the motor.

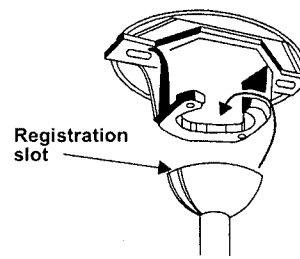

Figure 9

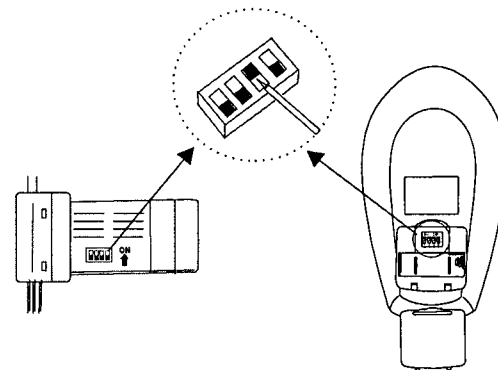

Figure 10

MAKING THE ELECTRICAL CONNECTIONS

Warning: The power should have already been disconnected. Follow the steps below to connect the fan to your household wiring. Use the wire nuts supplied with your fan. Secure the wire nuts with electrical tape. Make sure there are no loose strands or connections.

NOTE: The Hand Held Remote Control units included with your ceiling fan are equipped with 16 code combinations to prevent possible interference from or to other remote units. The frequency switches on your Receiver and Transmitter units have been preset at the factory. Please re-check to make sure the switches on both units are set to the same positions. The frequency settings should be changed only in case of interference or if a second or more remote controlled ceiling fans are installed in the same room. Any code combination will operate the ceiling fan and light as long as the Receiver and Transmitter units are set to the same codes (Fig. 10)

1. Insert Receiver into Hanger Bracket with the flat side of the Receiver facing the ceiling. (Fig. 11)

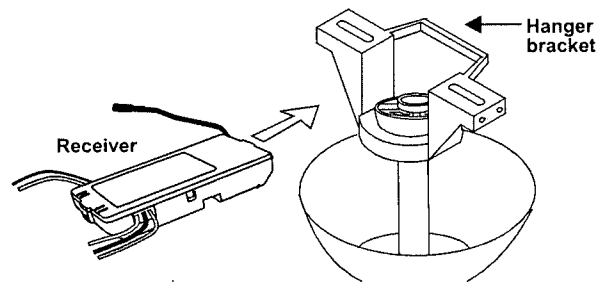

Figure 11

2. Motor to Receiver Electrical Connections:

A. Connect the WHITE wire from the fan to the WHITE wire marked "TO MOTOR N" from the Receiver.

B. Connect the BLACK wire from the fan to the BLACK wire marked "TO MOTOR L" from the Receiver.

C. Connect the BLUE wire from the fan to the BLUE wire marked "oscillation" from the Receiver. Proceed to secure all wire connections with the plastic wire nuts provided. (Fig. 12)

Note: Fan must be installed from a maximum distance of 40 feet from the transmitting unit for proper signal transmission between the transmitting unit and the fan's receiving unit.

3. Receiver to House Supply Wires Electrical Connections:

A. Connect the WHITE wire (Neutral) from the outlet box to the WHITE wire marked "AC in N" from the receiver.

B. Connect the BLACK wire (Hot) from the outlet box to the BLACK wire marked "AC in L" from the receiver. Secure all wire connections with the plastic wire nuts provided. (Fig. 12)

4. If your outlet box has a GROUND wire (Green or Bare Copper) connect this wire to the Hanger Ball and Hanger Bracket Ground wires. If your outlet box does not have a Ground Wire, then connect the Hanger Ball and Hanger Bracket Ground Wires together. Secure wire connection with the plastic wire nut provided. (Fig. 12)

5. Tuck connections neatly into ceiling outlet box.

6. Slide the canopy up to hanger bracket and place the key hole on the canopy over the screw on the hanger bracket, turn canopy until it locks in place at the narrow section of the key holes. (Fig. 13)

7. Align the circular hole on canopy with the remaining hole on the hanger bracket, secure by tightening the two set screws. Note: Adjust the canopy screws as necessary until the canopy and canopy cover are snug.

Warning: Make sure tab at bottom of hanger bracket is properly seated in groove of hanger ball before attaching canopy to bracket. Failure to properly seat tab in groove could cause damage to electrical wiring.

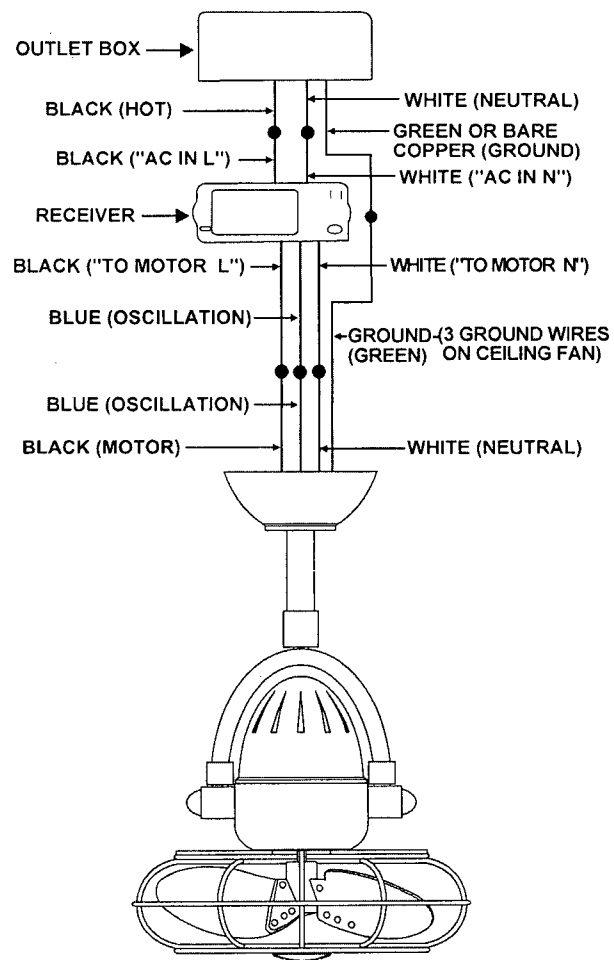

Figure 12

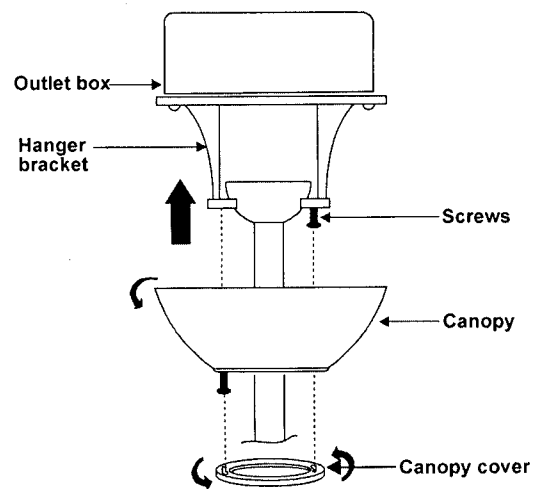

Figure 13

OPERATING THE REMOTE CONTROL

Install 12V MN21/A23 battery (included).

To prevent damage to transmitter, remove the battery if not used for long periods. (Fig. 14)

Restore Power to Ceiling Fan.

A. H, M, L Buttons:

These buttons are used to set the fan speeds as follows;

- L: Low Speed
- M: Medium Speed
- H: High Speed

B. OFF Button:

This button turns the fan off.

C. ACCESSORY Button:

This button is used to control the oscillating operation.

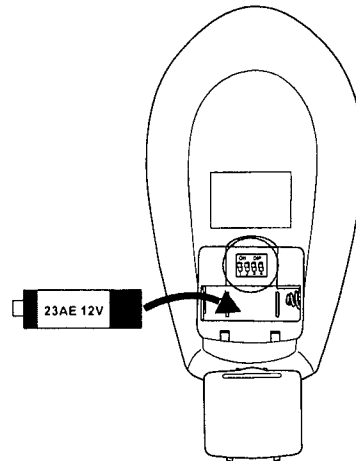

Figure 14

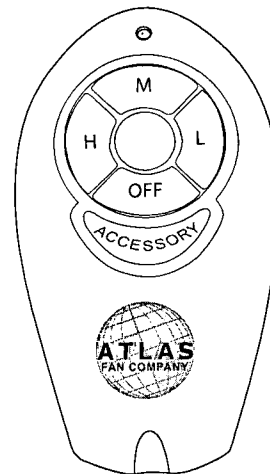

Figure 15

CARE OF AND TROUBLESHOOTING YOUR FAN

- 1. Check hardware bi-yearly.** Because of the fan's natural movement some connections may become loose over time. Check the support connections, brackets and blade attachments twice a year. Make sure they are secure. It is not necessary to remove fan from the wall.
- 2. Clean your fan periodically.** This will help to help maintain its new appearance over the years. Use only a lightly water-moistened, lint free cloth to avoid scratching the finish. Plated finishes are sealed with lacquer to minimize discoloration or tarnishing. Do not let rain or running water to come in contact with the fan. Rain or running water could damage the motor, wood blades or possibly cause an electrical shock.
- 3. There is no need to oil your fan.** The motor has permanently lubricated bearings.
- 4. Fan makes a vibration noise.** Check to see that all screws are tight in the fan cage connection to the motor face plate.
- 5. Fan vibrates or makes grinding noise as blades rotate.** Uninstall and reinstall the blades. Make sure that your fan head's set screw is counter-sunk into the bore hole in the flat part of the motor shaft. Be careful that the blade brackets themselves are not bent in this process. Do not operate your fan if it continues to vibrate. Contact your Atlas Fan Co purveyor if the re-installation of the blades does not resolve the problem.